

CAUTION: BLADES EXTREMELY SHARP

TEAM SYSTEM

Operating Instructions

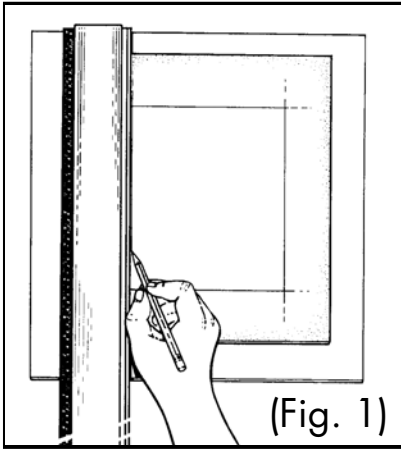

(Fig. 1)

Step 1 - Mark the Mat

Using the scale, mark the back of the mat for the exact border you want. (Fig. 1)

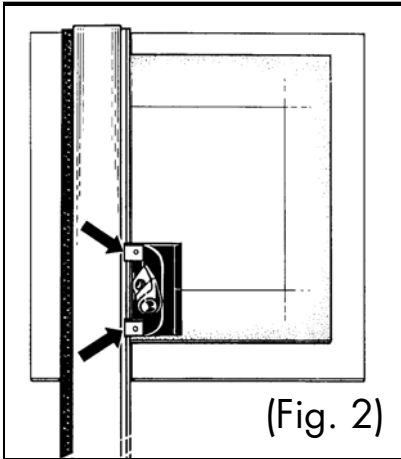

(Fig. 2)

Step 2 - Prepare the Team System

Place the mat face down on a backing sheet. (Any piece of scrap matboard can act as a backing sheet.) Place the guiderail exactly on the left hand border so that the outside edge of the channel is lined up along the pencil line. Attach the mat cutter to the guide rail by fitting the nylon guides over the raised edge of the channel.

Position the mat cutter so that the silver indicator line lines up with the bottom intersecting pencil line. (Fig. 2)

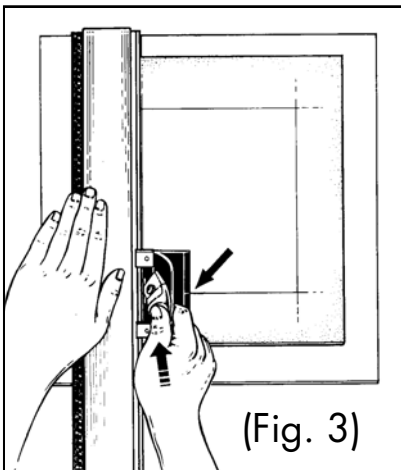

(Fig. 3)

Step 3 - Cut the Mat

Hold the guide rail firmly with your left hand. Place your thumb on the retractable blade holder and exert downward pressure forcing the blade into the mat. (Fig. 3)

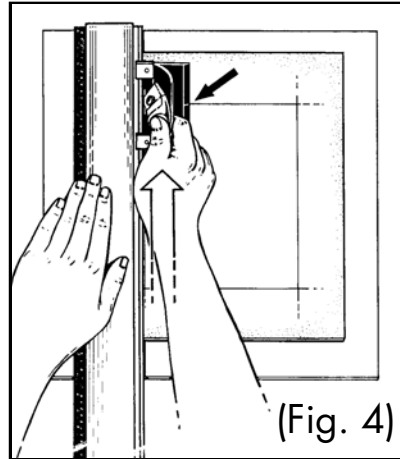

(Fig. 4)

Lower the heel of your hand behind the mat cutter and push away from yourself keeping pressure constant until the indicator line lines up with the top intersecting pencil line. (Fig. 4) *Helpful Hint: Position your left hand six inches in front of the cutter. Cut until the cutter is even with your hand, move your hand six more inches and continue cutting. Repeat the procedure until the end of the cut.*

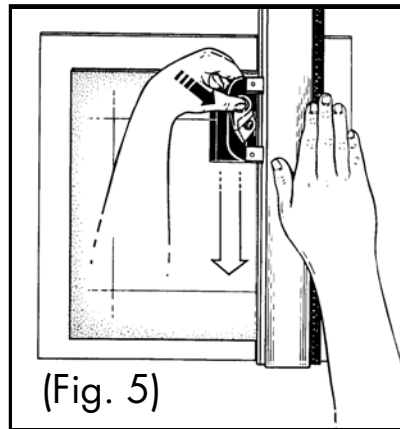

(Fig. 5)

To Cut Left Handed

Place the guide rail on the right hand border. Position the mat cutter so the indicator line lines up with the top intersecting pencil line. Place the tips of your fingers on the thumb divot, exert downward pressure and pull toward you until the indicator line line up with the bottom intersecting pencil line. (Fig. 5)

To Adjust the Blade Depth

There is a blade depth adjustment screw under the cutter. Turn the screw in to reduce the blade depth and turn the screw out to increase the blade depth.

To Change the Blade

Unscrew the blade holding knob. Slide the blade out of the slot and reverse or replace.



LOGAN[®]
GRAPHIC PRODUCTS, INC.
Tools for the Art of Framing
www.logangraphic.com

Logan Graphic Products, Inc.
1100 Brown Street,
Wauconda, IL 60084

Toll Free 1 800 331 6232

Made in the USA of Domestic
and Foreign Components.