



Basic Mat Cutter Maintenance

The following is general advice covering all Logan board mounted mat cutters.

Cleaning/Lubrication

Logan board mounted mat cutters *never require lubrication*. All contact between the cutting heads and the guide rails is taken up by Delrin plastic bearings that need no lubrication. Using a petroleum based lubricant can chemically soften the Delrin plastic causing them to bind on the guide rail instead of smoothly glide. All that is necessary is to periodically clean the guide rail with an evaporating solvent such as lighter fluid or alcohol.

Bearing Replacement

Over time the Delrin bearings on Logan cutting heads may wear causing a wobble between the cutting head and Guide Rail. They are replaceable. On Logan professional equipment such as model #310, #350, #600, #650-1 & #660-1, the Delrin plastic bearings are free for the lifetime of the machine. (Part #115/162A) On the art material mat cutters such as the #301, #401 and #700SGM, the bearings and screws can be replaced. (Part #501/162)

Storing Mat Cutters

Always store a Logan board mounted mat cutter flat when not in use. Never lean the mat cutter up against a wall for any period of time as this can cause the base board to warp out of shape. Remove the squaring arm if the mat cutter is to be stored for a period of time. But remember to use the line-up tool when re-installing it.

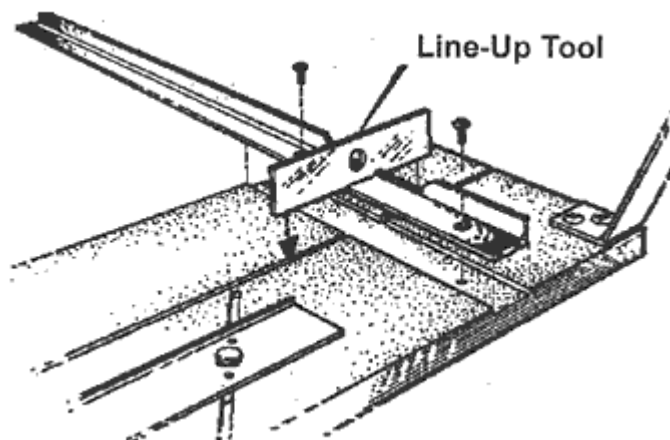

Framers Corner,
Cedar Court,
Walker Road,
Hilltop Industrial Estate,
Bardon, Leicestershire,
LE67 1TU

Tel: 01530 516925
Fax: 01530 516929
Email: <mailto:sales@framerscorner.co.uk>
Website: <http://www.framerscorner.co.uk/>